

STATIONARY GLASS

TABLE OF CONTENTS

	page	page
SERVICE PROCEDURES		
WINDSHIELD SAFETY PRECAUTIONS	6	
REMOVAL AND INSTALLATION		
WINDSHIELD	6	
		QUARTER GLASS 8

SERVICE PROCEDURES

WINDSHIELD SAFETY PRECAUTIONS

DESCRIPTION

WARNING: DO NOT OPERATE THE VEHICLE WITHIN 24 HOURS OF WINDSHIELD INSTALLATION. IT TAKES AT LEAST 24 HOURS FOR URETHANE ADHESIVE TO CURE. IF IT IS NOT CURED, THE WINDSHIELD MAY NOT PERFORM PROPERLY IN AN ACCIDENT.

URETHANE ADHESIVES ARE APPLIED AS A SYSTEM. USE GLASS CLEANER, GLASS PREP SOLVENT, GLASS PRIMER, PVC (VINYL) PRIMER AND PINCH WELD (FENCE) PRIMER PROVIDED BY THE ADHESIVE MANUFACTURER. IF NOT, STRUCTURAL INTEGRITY COULD BE COMPROMISED.

DAIMLERCHRYSLER DOES NOT RECOMMEND GLASS ADHESIVE BY BRAND. TECHNICIANS SHOULD REVIEW PRODUCT LABELS AND TECHNICAL DATA SHEETS, AND USE ONLY ADHESIVES THAT THEIR MANUFACTURES WARRANT WILL RESTORE A VEHICLE TO THE REQUIREMENTS OF FMVSS 212. TECHNICIANS SHOULD ALSO INSURE THAT PRIMERS AND CLEANERS ARE COMPATIBLE WITH THE PARTICULAR ADHESIVE USED.

BE SURE TO REFER TO THE URETHANE MANUFACTURER'S DIRECTIONS FOR CURING TIME SPECIFICATIONS, AND DO NOT USE ADHESIVE AFTER ITS EXPIRATION DATE.

VAPORS THAT ARE EMITTED FROM THE URETHANE ADHESIVE OR PRIMER COULD CAUSE PERSONAL INJURY. USE THEM IN A WELL-VENTILATED AREA.

SKIN CONTACT WITH URETHANE ADHESIVE SHOULD BE AVOIDED. PERSONAL INJURY MAY RESULT.

ALWAYS WEAR EYE AND HAND PROTECTION WHEN WORKING WITH GLASS.

CAUTION: Protect all painted and trimmed surfaces from coming in contact with urethane or primers.

Be careful not to damage painted surfaces when removing moldings or cutting urethane around windshield.

OPERATION

The windshield is attached to the window frame with urethane adhesive. The urethane adhesive is applied cold and seals the surface area between the window opening and the glass. The primer adheres the urethane adhesive to the windshield.

It is difficult to salvage a windshield during the removal operation. The windshield is part of the structural support for the roof. The urethane bonding used to secure the windshield to the fence is difficult to cut or clean from any surface. If the moldings are set in urethane, it would also be unlikely they could be salvaged. Before removing the windshield, check the availability of the windshield and moldings from the parts supplier.

REMOVAL AND INSTALLATION

WINDSHIELD

The windshield is positioned in the reveal molding and is bonded to the windshield frame with urethane adhesive. The windshield interior trim molding is positioned onto the inner windshield frame pinch-weld.

REMOVAL

(1) Cover body surface areas with protective covering to avoid paint damage and extra clean-up time.

(2) Remove the windshield wiper arms and the rearview mirror.

(3) Using a razor knife, slide the blade between the windshield glass and the inboard edge of the reveal molding.

(4) Cut around the interior perimeter of the reveal molding and sever the cap of the reveal molding.

REMOVAL AND INSTALLATION (Continued)

(5) Using a cold knife, cut the urethane around the perimeter of the windshield (Fig. 1).

(6) Remove the windshield glass from the frame (Fig. 2).

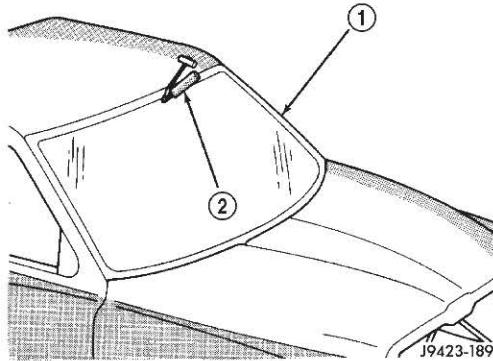

Fig. 1 Cutting Urethane Around Windshield—Typical

- 1 - WINDSHIELD
2 - COLD KNIFE

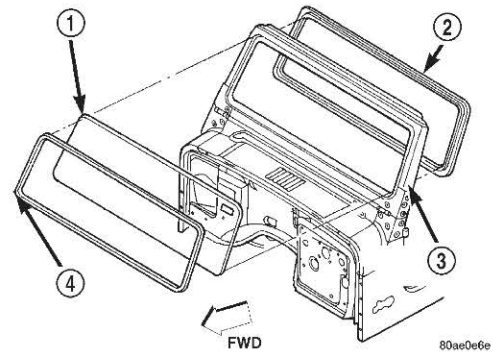

Fig. 2 Windshield

- 1 - WINDSHIELD
2 - INNER TRIM MOLDING
3 - WINDSHIELD FRAME
4 - WINDSHIELD MOLDING

INSTALLATION

(1) Trim the urethane from the pinchweld flanges. Leave a 3 mm (0.1 in.) level base of urethane on the pinchweld flanges.

(2) Place replacement windshield into windshield opening and position glass in the center of the opening against pinchweld flange.

(3) Verify the glass lays evenly against the pinchweld fence at the sides, top and bottom of the

replacement windshield. If not, the pinchweld flange must be formed to the shape of the new glass. Next, make alignment marks on glass and body with a grease pencil.

(4) Remove replacement windshield from windshield opening.

(5) Position the windshield inside up on a suitable work surface with two padded, wood 10 cm by 10 cm by 50 cm (4 in. by 4 in. by 20 in.) blocks, placed parallel 75 cm (2.5 ft.) apart (Fig. 3).

WARNING: DO NOT USE SOLVENT BASED GLASS CLEANER TO CLEAN WINDSHIELD BEFORE APPLYING GLASS PREP AND PRIMER. POOR ADHESION CAN RESULT.

(6) Clean inside of windshield with ammonia based glass cleaner and lint-free cloth.

(7) Apply molding to perimeter of windshield. The butt weld of the molding should be centered at the bottom edge of the windshield.

(8) Apply Glass Prep adhesion promoter 25 mm (1 in.) wide around perimeter of windshield and wipe with clean/dry lint-free cloth until no streaks are visible.

(9) Apply Glass Primer 25 mm (1 in.) wide around perimeter of windshield. Allow at least three minutes drying time.

(10) Apply Pinchweld primer 15 mm (.75 in.) wide around the windshield fence. Allow at least three minutes drying time.

(11) Apply a urethane bead (Fig. 4) on the pinchweld flange surface area 6 mm (.25 in.) from the outboard edge.

CAUTION: Be prepared to install the windshield glass immediately after applying the adhesive. The adhesive begins to cure within 10-15 minutes.

(12) Align the windshield with the grease pencil marks and position windshield on pinchweld flanges.

(13) Push the windshield glass inward until the reveal molding is seated on the windshield frame. Use care to avoid excessive squeeze-out of adhesive.

(14) Open windows and liftgate to prevent pressure build-up while the urethane is curing.

(15) Starting in each corner, apply 150 mm (6 in.) lengths of 50 mm (2 in.) masking tape spaced 250 mm (10 in.) apart to hold windshield in place until urethane cures.

(16) Install the rearview mirror on the mirror button.

(17) Install the wiper arms.

(18) After urethane has cured, remove tape strips and water test windshield to verify repair.

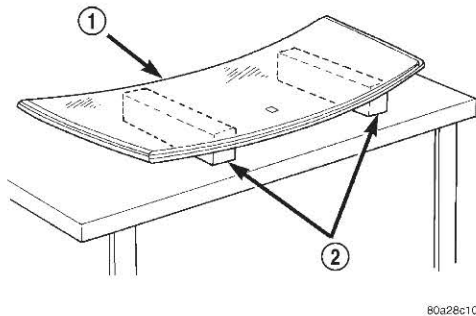
REMOVAL AND INSTALLATION (Continued)**Fig. 3 Work Surface Set up and Molding Installation**

- 1 - WINDSHIELD AND MOLDINGS
2 - BLOCKS

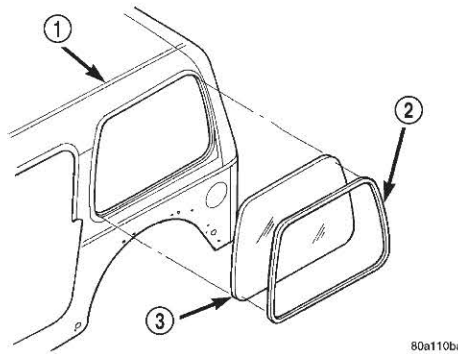
**Fig. 5 Hard Top Quarter Glass**

- 1 - HARD TOP
2 - QUARTER GLASS REVEAL MOLDING
3 - QUARTER GLASS

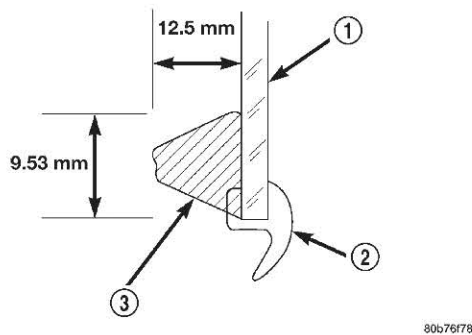
**Fig. 4 Urethane Bead**

- 1 - WINDSHIELD
2 - MOLDING
3 - URETHANE BEAD

QUARTER GLASS**REMOVAL**

- (1) Cover surface areas with protective covering to avoid paint damage and extra clean-up time.
- (2) Using a razor knife, slide the blade between the quarter glass and the inboard edge of the reveal molding.
- (3) Cut around the interior perimeter of the reveal molding and sever the cap of the reveal molding.
- (4) Using a cold knife, cut the urethane around the perimeter of the quarter glass.
- (5) Remove the quarter glass from the opening (Fig. 5).

INSTALLATION

- (1) Trim the urethane from the quarter glass opening fence. Leave a 3 mm (0.1 in.) level base of urethane on the quarter glass opening fence.
- (2) Place replacement quarter glass into quarter glass opening and position glass in the center of the opening against fence.
- (3) Verify the glass lays evenly against the fence at the sides, top and bottom of the replacement quarter glass. Next, make alignment marks on glass and top with a grease pencil.
- (4) Remove replacement quarter glass from opening.
- (5) Position the quarter glass inside up on a suitable work surface.

WARNING: DO NOT USE SOLVENT BASED GLASS CLEANER TO CLEAN QUARTER GLASS BEFORE APPLYING GLASS PREP AND PRIMER. POOR ADHESION CAN RESULT.

- (6) Clean inside of quarter glass with ammonia based glass cleaner and lint-free cloth.
- (7) Clean the outer edge of the window glass with naphtha or a similar product.
- (8) Apply molding to perimeter of quarter glass. The butt weld of the molding should be centered at the bottom edge of the quarter glass.
- (9) Apply Glass Prep adhesion promoter 25 mm (1 in.) wide around perimeter of the quarter glass and wipe with clean/dry lint-free cloth until no streaks are visible.
- (10) Apply Glass Primer 25 mm (1 in.) wide around perimeter of quarter glass. Allow at least three minutes drying time.

REMOVAL AND INSTALLATION (Continued)

(11) Apply Pinchweld primer 15 mm (.75 in.) wide around the quarter glass fence. Allow at least three minutes drying time.

(12) Apply a 10 mm (0.4 in.) diameter bead of urethane to the center of the quarter glass fence surface area.

CAUTION: Be prepared to install the quarter glass immediately after applying the adhesive. The adhesive begins to cure within 10-15 minutes.

(13) Align the quarter glass with the grease pencil marks and position quarter glass on fence.

(14) Push the quarter glass inward until the reveal molding is seated on the hardtop. Use care to avoid excessive squeeze-out of adhesive.

(15) Open windows and liftgate to prevent pressure build-up while the urethane is curing.

(16) Apply 150 mm (6 in.) lengths of 50 mm (2 in.) masking tape spaced 250 mm (10 in.) apart to hold quarter glass in place until urethane cures.

(17) After urethane has cured, remove tape strips and water test quarter glass to verify repair.